

ARSVD00396

Cornerstone

ISDN Voice Port Installation Guide

Release 8.1 Standard 1.0 September 2001

Front cover



Cornerstone

ISDN Voice Port Installation Guide

Document number: ARSVD00396
Release 8.1 Standard 1.0
September 2001

© 2001 ARRIS
All rights reserved

The information in this document is subject to change without notice. The statements, configurations, technical data, and recommendations in this document are believed to be accurate and reliable, but are presented without express or implied warranty. Users must take full responsibility for their applications of any products specified in this document. The information in this document is proprietary to ARRIS.

ARRIS, ARRIS Interactive, and Voice Port are trademarks of ARRIS Licensing Company. Cornerstone is a registered trademark of ARRIS Licensing Company. AccessNode is a registered trademark of Nortel Networks. All other trademarks and registered trademarks are the property of their respective holders.

Title page

Publication history

September 2001

Release 8 Standard 1.0 version of this document for CsV08.

October 1999

Release 7 Preliminary 0.1 version of this document for CsV07.

Left even

Contents

| | |
|--|----------|
| ISDN Voice Port overview | 1 |
| ISDN Voice Port functions | 1 |
| Features and service attributes | 2 |
| System requirements | 3 |
| Safety precautions | 3 |
| Installing the ISDN Voice Port | 1 |
| Package contents | 1 |
| Procedure 2-1 | |
| Mounting the ISDN Voice Port | 2 |
| Procedure 2-2 | |
| Connecting ISDN terminating units | 3 |
| Action | 4 |
| Procedure 2-3 | |
| Inserting the battery | 9 |
| Procedure 2-4 | |
| Replacing the battery | 10 |
| Procedure 2-5 | |
| Decommissioning the ISDN Voice Port | 11 |
| Operating the ISDN Voice Port | 1 |
| Default operating state before commissioning | 1 |
| Understanding the ISDN Voice Port's status information | 1 |

Left even

| | |
|---|----------|
| RF Module Status LED | 2 |
| 3 | |
| Battery status | 3 |
| Maintenance, cleaning and servicing | 5 |
| Technical Data, Standards and Certifications | 1 |
| 1 | |
| Technical data | 1 |
| Standards and certifications | 4 |
| Appendix A: Wiring the S0-bus types | 1 |
| Appendix B: Terms | 1 |

About this document

This guide describes the installation and operating procedures for the Cornerstone ISDN Voice Port.

When installing a new ISDN Voice Port, read and perform the procedures in the following chapters:

- “ISDN Voice Port overview” on page 1-1
- “Installing the ISDN Voice Port” on page 2-1

“Operating the ISDN Voice Port” on page 3-1 contains important information regarding the operation of the ISDN Voice Port.

To avoid damage of equipment and service interruptions, follow all caution warnings provided with this product, as well as procedures established by your company.

Left even

Samples of danger and caution warnings



Danger

Risk of personal injury

A danger warning informs the reader of a risk of personal injury.



Caution

Risk of service interruption or equipment damage

A caution warning informs the reader of a risk of service interruption or equipment damage.



Danger

Risk of electric shock

This warning advises you of a possible electrical hazard. When you see this warning proceed with care, to avoid personal injury.

ISDN Voice Port overview

This chapter describes the ISDN Voice Port functions, features, and system requirements.

ISDN Voice Port functions

The ISDN Voice Port (ISDN: Integrated Services Digital Network) allows you to connect to the cable-television network with both your TV-set and your ISDN terminals. The connection of the ISDN terminating units to the telephony headend is accomplished using an HFC (HFC: Hybrid Fiber Coax) or pure coax network. The network allows your cable television network operator to provide you with cable TV as well as ISDN basic rate telephony services.

During normal operation the ISDN Voice Port is locally powered using an internal mode-switched power pack. This power pack feeds the RF module, the ISDN module and the ISDN terminating units connected to the S_0 -bus and provides the battery of the ISDN Voice Port with the necessary charging voltage. In case of a local power failure the ISDN Voice Port automatically switches to emergency mode. In this situation, the battery contained in the ISDN Voice Port enclosure ensures standby operation for at least one ISDN terminal (designated as the emergency phone) for about 2 hours or allows an active call to continue for approximately 30 minutes. Therefore you will be able to originate an emergency call using the ISDN Voice Port during a local power outage.

Left even

Figure 1-1: ISDN Voice Port

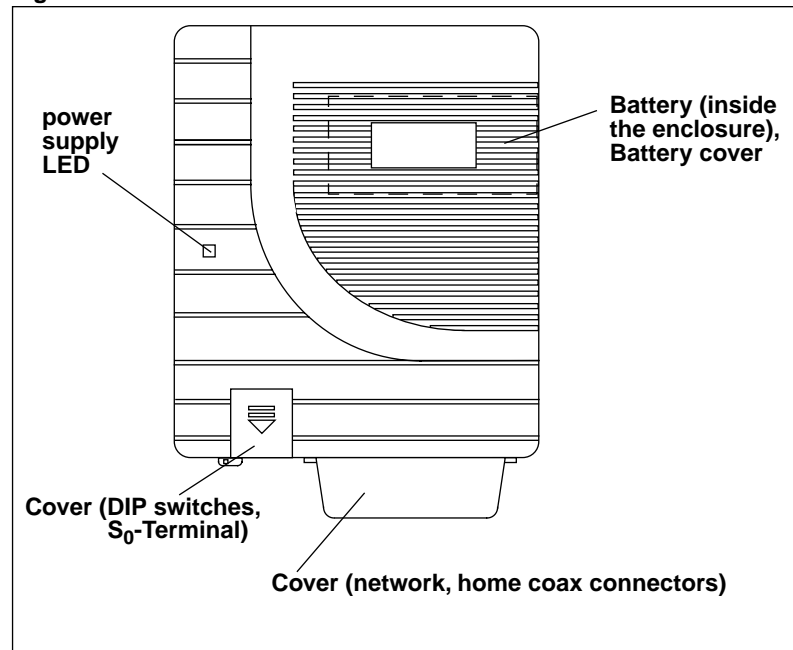

Features and service attributes

The ISDN Voice Port has the following features and service attributes:

Features

- ISDN telephony network termination for cable-TV networks
- Digital S₀-interface (physical: wire terminal; RJ-45 connectors)
- Battery backup as emergency power supply
- Remote configuration via HFC or coax cable networks
- Remote diagnostics and unit testing from the cable-TV headend

Service attributes

- Country-specific and dependent on the network operator
- The ISDN Voice Port meets the standards stated in chapter 4
- The ISDN Voice Port meets the requirements of the CE-symbol

System requirements

The ISDN Voice Port requires the following items for proper operation:

- An appropriately installed local power supply (230 V AC / 50 Hz).
- A cable television / cable telephony network port for service access provided by your cable TV network operator.
- Devices must be equipped with appropriate connectors for the ISDN Voice Port interfaces (TV, S₀-bus).
- Terminating customer premise equipment should be marked with the CE-symbol and be connected only via the appropriate interfaces.

Safety precautions



CAUTION

Before installing and commissioning the ISDN Voice Port, please read these operating instructions thoroughly. These instructions will help you use the device to its full extent and avoid damage resulting from improper application.

- The ISDN Voice Port has been manufactured using state-of-the-art technology and complies with all necessary safety regulations.
- Please make sure that the device is operated only in the appropriate environment and that all operating instructions are observed at all times.
- Only authorized personnel are allowed to service the ISDN Voice Port. The ISDN Voice Port contains no components serviceable by the end subscriber.
- After connecting the device, install the correct supply voltage (see “Technical Data, Standards and Certifications” on page 4-1)
- The ISDN Voice Port contains no fuses for interrupting the local power voltage. The device must be placed within 2 meters of the power outlet.
- Care should be taken when installing power and the CATV (CATV: CABLE TeleVision) network connection cables in order to avoid accidents (such as tripping over the cables).

Left even

1-4 ISDN Voice Port overview

- The device shall be operated only within a temperature range of +5°C to +40°C.
- In case of device failure please contact the manufacturer or the representative in your vicinity. When doing so, please have the following data available: ISDN Voice Port no. and date of manufacturing (see label on the ISDN Voice Port) and condition of the LEDs on the ISDN Voice Port (see “Understanding the ISDN Voice Port’s status information” on page 3-1).

In addition to these safety instructions the later chapters of this manual contain installation and operation instructions.

Installing the ISDN Voice Port

This chapter explains how to install the ISDN Voice Port.

Package contents

The ISDN Voice Port package includes the following components:

- ISDN Voice Port unit
- Battery
- Coax connector cover cap
- Safety screws
- Drilling template
- Screws and dowels for wall mounting
- Operating manual

Left even

Procedure 2-1 Mounting the ISDN Voice Port

The ISDN Voice Port is mounted to the wall in the customer's house or apartment near the cable-TV network outlet. The device should not be exposed to direct sun light or humidity.

Requirements

Please note the following items before mounting the ISDN Voice Port:

- When determining the installation location, make sure that there are no concealed supply lines of any kind (power, gas, water, telecommunications) near the point of installation.
- The power cable length is 1.5 m.
- Allow a distance of about 20 cm to the wall or any obstacle on the right side of the Voice Port so the battery compartment can be opened.

Action

Follow the installation instructions below to mount the ISDN Voice Port on the wall at the subscriber premises:

- 1 After determining the installation location, use the drilling template to mark the position of the mounting holes to be drilled.
- 2 Drill the required holes using a 5.5 mm drill bit.
- 3 Insert the dowels S6.
- 4 Screw the 3.5 mm recessed-head screws into the wall until the distance between wall and screw head is approximately 3 mm.
- 5 Place the device over the protruding screw heads and snap it into place.

—end—

Procedure 2-2 Connecting ISDN terminating units

The ISDN terminating equipment connects to the ISDN Voice Port using an S₀-bus. The ISDN Voice Port gives you two fully-featured B-channels offering a transmission rate of 64 kb/s each for voice signals or data packets.

Requirements

The ISDN devices can be connected to the ISDN Voice Port using two western jacks RJ 45. These western jacks are found on the left side of the ISDN Voice Port bottom and are marked with “ISDN S₀”. Alternatively, the terminating units can be wired using four-pole spring terminal contacts. The wire terminal is available under the S₀-bus wire terminal cover located on the bottom left on the ISDN Voice Port’s front face.

Figure 2-1: ISDN Voice Port (bottom view) - showing port connectors for cable routing

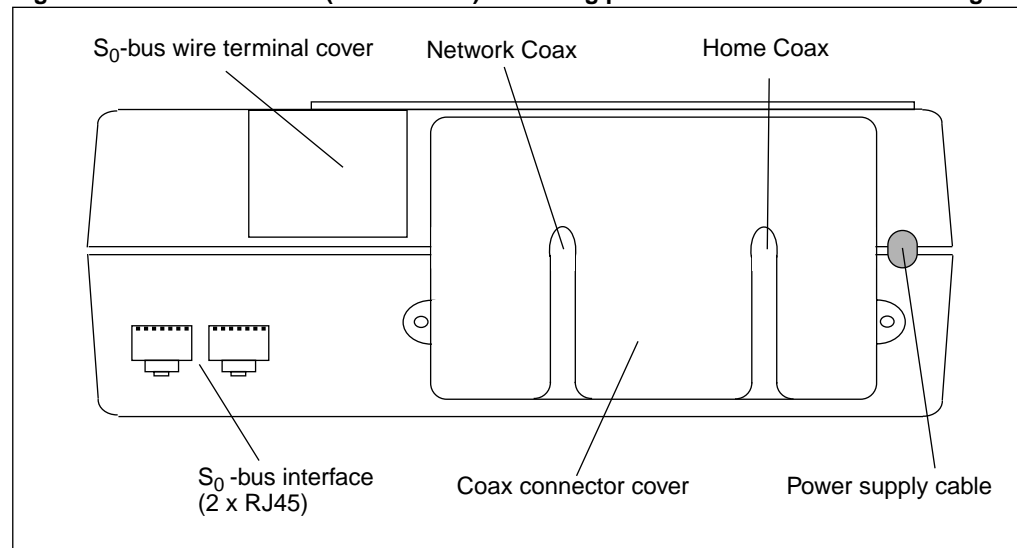

—continued—

Right odd

Left even

2-4 Installing the ISDN Voice Port

Procedure 2-2 (continued)

Connecting ISDN terminating units

Action

To connect to the S_0 -bus using the wire terminal instead of the RJ-45s, perform the following:

- 1** Open the cover at the bottom edge of the device right beside the western jacks: Press onto the arrow there and push the cover down simultaneously.
- 2** Connect the bus wires to the wire terminals.
- 3** Replace the cover making sure that it safely snaps into place and that the wire terminal is fully covered.
- 4** Install the terminating resistors (TR - Terminating Resistor) at the ends of the S_0 -bus. At the bus end to which the ISDN Voice Port is connected this will be realized by Voice Port internal DIP-switches (see "Setting the DIP switches" on page 2-7). At the other end, the wire pairs "Send" and "Receive" shall be electrically terminated by 100 Ohm resistors each.

The S_0 -bus can be operated in one of two configurations (to select the mode of operation use the Voice Port internal DIP-switches (see "Setting the DIP switches" on page 2-7):

—continued—

Procedure 2-2 (continued)

Connecting ISDN terminating units

- a. *as short passive bus (default setting)*: Up to eight ISDN-terminating units can be connected to the S₀-bus. Two of them can simultaneously establish a connection. Additionally this bus configuration allows you to run up to four ISDN terminals without external power supply. The short passive bus configuration corresponds to the so-called point-to-multipoint connection.

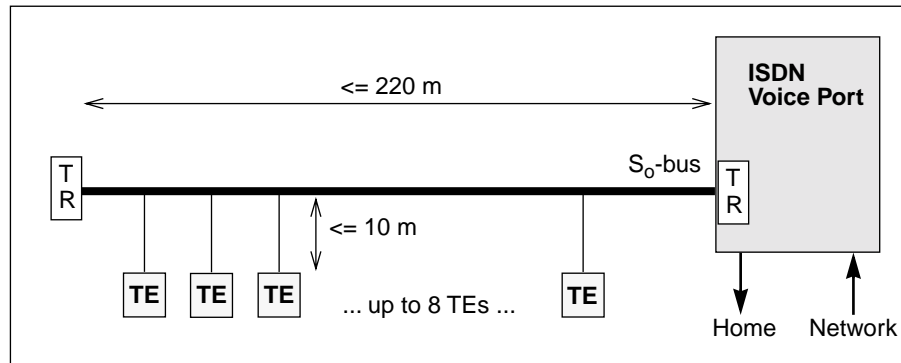
Figure 2-2: Short passive bus; point-to-multipoint configuration

—continued—

Right odd

Left even

Procedure 2-2 (continued)

Connecting ISDN terminating units

- b. *as extended passive bus*: The ISDN Voice Port can be used to connect a ISDN PABX to the network via a basic rate access. This configuration is called a point-to-point configuration. Lines managed by the PABX compete for use of the two B-channels provided by the basic rate access the ISDN Voice Port manages. The connection of the PABX is configured using the DIP switches within the ISDN Voice Port (see "Setting the DIP switches" on page 2-7). The ISDN Voice Port allows direct inward dialling to lines managed by the ISDN PABX.

Figure 2-3: Extended passive bus; point-to-point configuration

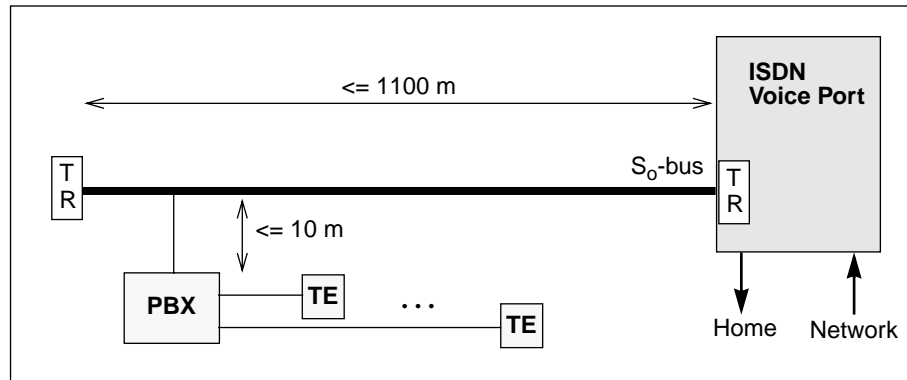

Note: The wiring schemes for the bus configurations are shown in the appendix.

—continued—

Procedure 2-2 (continued)

Connecting ISDN terminating units**Right odd****Connecting the power supply**

- 5 The ISDN Voice Port connects to the local 230 V AC power supply for its operating voltage. The power cable on the ISDN Voice Port is equipped with a universal plug that allows connecting the device to wall power outlets in all European countries.

Connecting the TV set

- 6 To connect your TV set to the ISDN Voice Port, first remove the cover cap of the coax connectors. To do this, unscrew both screws at the bottom of the ISDN Voice Port that are holding the cover cap in place. Now the cap can be lifted at the front and be unhinged.
- 7 Your TV set connects to the ISDN Voice Port via a standard coax cable equipped with an F-plug. The connecting socket is at the right bottom side next to the power lead and is marked with "TV". Slip the plug onto the socket and bolt it down. Alternatively, the TV set can be connected by means of a coax adaptor. Having connected both TV set and the cable TV network connection (see below), hinge the cover cap back into place. Finally shut the cover cap and tighten the two screws.

Connecting the Voice Port to the CATV network

- 8 Use an F-plug coax cable to connect the ISDN Voice Port to the cable-television network. Connect the F-plug to the bottom left socket (marked with the aerial antenna symbol) on the ISDN Voice Port and tighten the F-plug's connector ring. Refer to step 6 for removing and replacing the coax cover cap.

Setting the DIP switches

- 9 To configure the ISDN Voice Port, you must set the DIP switches according to the selected S₀-bus configuration. The DIP switches are located in the connection field on the ISDN Voice Port enclosure's left bottom side, behind the cover that conceals the wire terminal for the S₀-bus. In the default configuration the DIP switches are set so the 100 Ohm terminating resistors are active on the "Send" and "Receive" lines for the passive bus. If you want to run the S₀-bus in another operating mode the DIP-switch settings must be changed as shown in Table 2-1 on page 2-8.

—continued—

Left even

Procedure 2-2 (continued)
Connecting ISDN terminating units

Figure 2-4: Position of the ISDN Voice Port DIP switches

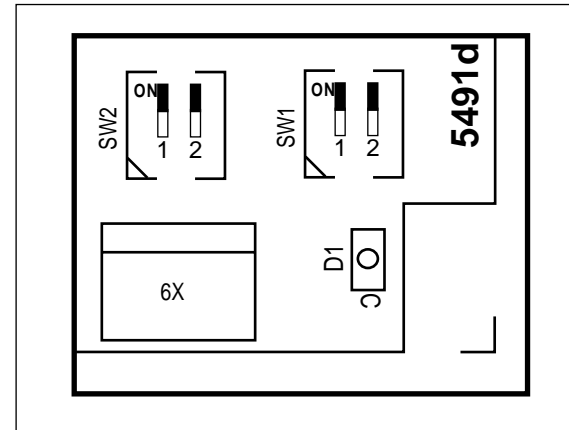

Table 2-1: DIP switch settings (default settings in bold letters)

| Switch | Position ON | Position OFF |
|--------|--|---|
| SW 2-1 | 100 Ohm terminating resistor ON | 100 Ohm terminating resistor OFF |
| SW 2-2 | 100 Ohm terminating resistor ON | 100 Ohm terminating resistor OFF |
| SW 1-1 | Mode switch PIN RF module | Not used |
| SW 1-2 | Point-to-point connection (extended passive bus) | Point-to-multipoint connection (short passive bus) |

Note: Terminating resistors should be activated on the ISDN Voice Port, regardless of what type of S₀-bus configuration is used.

—end—

Procedure 2-3 Inserting the battery

Right odd

In case of a local power failure the lead-gel battery integrated in the ISDN Voice Port enclosure ensures emergency standby operation for at least one ISDN terminating device (such as an ISDN phone) for a two-hour period. An active call will be kept up for approximately half an hour. After this period, once the battery is discharged, the ISDN Voice Port switches to bypass mode. In this mode only the TV-signal is accessible, which is always transmitted to the TV socket, regardless of the ISDN Voice Port's telephony operating state. Please be aware that after replacement of the battery the ISDN Voice Port does not return in emergency mode. Normal operation can only resume once the local power has been reconnected.

Requirements

The pre-charged battery is delivered separately and has to be inserted and connected upon initial commissioning of the ISDN Voice Port. Provided that the ISDN Voice Port was mounted correctly (see "Mounting the ISDN Voice Port" on page 2-2) the battery can be replaced without unmounting the ISDN Voice Port enclosure.

Action

To install the battery execute the following steps:

- 1 Open the cover of the battery compartment on the front side of the device, pressing the left cover edge inwards and simultaneously sliding it to the right. On the inside of the accumulator compartment cover there is a sticker. Observe the mounting instructions and safety regulations that are listed there.
- 2 Insert the battery into the compartment so that the connecting wires with the pre-mounted plug adaptor point to the left.
- 3 Connect the battery socket of the ISDN Voice Port to the battery's plastic plug.

—end—

Left even

Procedure 2-4 Replacing the battery

To replace the battery perform the following steps:

- 1 Remove the discharged battery from the compartment by placing a finger between the right side of the battery and the enclosure wall and pulling the battery out.
- 2 Disconnect the ISDN Voice Port's battery socket from the battery plug and connect it to the new battery.



Caution

Do not force the battery's plug into the ISDN Voice Port's battery socket. The plug is keyed and can only be connected in the correct orientation. Forcing a connection between the plug and the socket can result in a reversal of polarity, which will discharge the battery and is likely to severely damage the ISDN Voice Port.

- 3 Replace the cover on the battery compartment and slide the cover to the left until it snaps into place.

—end—

The ISDN Voice Port contains a charging circuit, which, under normal circumstances and continued availability of the local power supply, maintains the battery at a fully charged level. Should the battery ever be discharged it takes about 20 hours of continuous charging time for it to become fully charged again. In the event of an unforeseen local power failure, the ISDN Voice Port automatically switches from normal operation to emergency mode. Existing telephone connections are maintained at this time. After local power has been restored the battery will be recharged automatically.

The lifetime of the accumulator depends to a great extent on its capacity. The capacity of the battery used to power the ISDN Voice Port shall be no less than 1.3 Ah. If replaced, the new battery must comply with the technical specifications given in this manual (see "Technical Data, Standards and Certifications" on page 4-1).

Procedure 2-5 Decommissioning the ISDN Voice Port

Right odd

To unmount and decommission the ISDN Voice Port perform the following actions:

- 1 Disconnect the power.
- 2 Disconnect the connections to the ISDN terminals and to the CATV network. (It is not necessary to remove the ISDN Voice Port integrated battery; the battery is protected against deep discharge by an appropriate circuit.)
- 3 After all cables are disconnected the ISDN Voice Port can be taken off the wall.

—end—

Left even

Operating the ISDN Voice Port

This chapter explains how to operate the ISDN Voice Port.

Default operating state before commissioning

Having unpacked the ISDN Voice Port, you will find the device in the following condition:

- The battery is not installed.
- The bus is configured as short passive bus.

After applying local power all functions of the ISDN Voice Port can be used. To fully activate the S₀-bus and the attached ISDN terminals (after commissioning of the ISDN access by the operator is completed) it may be necessary to lift the handset off the terminal and replace it again after about 10 s.

Note: If difficulties should persist with receiving dialtone on the ISDN terminals contact your service provider for help.

Understanding the ISDN Voice Port's status information

This section explains how to interpret the RF module and battery status information provided by the ISDN Voice Port.

Left even

RF Module Status LED

After removing the angled cover of the S₀-bus wire terminals on the lower left of the ISDN Voice Port enclosure, a SMD LED on the ISDN module PCB becomes visible. It's status indicates the overall state of the ISDN Voice Port. While being mounted on the ISDN module the LED is controlled by the ISDN Voice Port's RF module. A service technician at the subscriber site uses this indicator to determine the condition of the RF module and it's connection to the network during installation or maintenance.

Table 3-1 on page 3-2 lists the possible states indicated by the RF module status LED.

Table 3-1: Interpreting the RF module status LED

| LED status | Interpretation |
|---|---|
| <i>Normal operating states</i> | |
| LED on | Local power on, searching for valid downstream carrier path signal |
| Three flashes | ISDN Voice Port marshalling in to the network |
| One flash | ISDN Voice Port operational, upstream and downstream carrier paths established, phone line in service |
| <i>Error states</i> | |
| LED off | Local power off |
| Four flashes | Upstream network problem (see note) |
| Two flashes | ISDN Voice Port marshalled in, but line not available (no lines provisioned) |
| <i>Note:</i> The ISDN Voice Port is locked onto the correct upstream and downstream carrier paths but due to a problem with an upstream entity it cannot get information back to the headend. | |

Note: The time between LED status indications changes over time. For the first hour after an ISDN Voice Port status change the LED will indicate the status every 5 s. Once the hour has passed with no further ISDN Voice Port state changes, the LED will indicate status using the signals listed in Table 3-1 on page 3-2 only every 15 s.

Battery status

The RF-module distinguishes four battery states:

- Battery okay
- Replace battery
- Local power AC voltage breakdown
- No battery

The operator of the headend managing the CATV network branch to which the ISDN Voice Port is attached can remotely check the state of the battery and the overall ISDN Voice Port. This ability is important to be able to guarantee quality of service at all times.

On the ISDN Voice Port itself, the power supply status LED can be used to determine the battery state.

The power supply status LED

The dual colored LED on the ISDN Voice Port enclosure's front face indicates the power supply situation of the ISDN Voice Port. See Table 3-2 on page 3-4 for details on the states of this LED indicator.

Left even

Table 3-2: Operating states of the-LED for status display

| LED status | Local power, 230 V | Accumulator |
|--|--------------------|---|
| Green LED on | Okay | Okay |
| Green LED flashing at 4Hz | Okay | Battery low |
| Green LED flashing at 6Hz | Okay | No battery |
| Red LED on | No local power | Battery operation (emergency mode), battery charged |
| Red LED flashing at 4Hz | No local power | Battery operation (emergency mode), battery low |
| Red LED flashing at 6Hz (see note) | No local power | Battery operation (emergency mode), battery empty |
| <i>Note:</i> This state is seen for a maximum duration of 2-3 seconds. | | |

Maintenance, cleaning and servicing

The ISDN Voice Port is a largely maintenance-free device. For cleaning the device, please use a soft, dry or medium-wet cloth. Do not use any aggressive detergents or cleansing agents.

If it becomes necessary to open the enclosure the ISDN Voice Port must be taken from the wall (see “Mounting the ISDN Voice Port” on page 2-2). Now remove the four screws which are accessible from the backside of the device. Looking at the backside of the device, you will find a small nut on the right-bottom side. Insert a screwdriver into the nut and turn it 30° to the right (clockwise). Upon this, the cover locking gets disengaged and the lid can be removed.



Caution

There are no end user serviceable parts contained in the ISDN Voice Port. Any necessary maintenance work on the device must be executed by qualified personnel only!

Right odd

Left even

Technical Data, Standards and Certifications

This chapter lists the technical data, standards and specifications of the ISDN port.

Technical data

Table 4-1: Technical data for ISDN port enclosure

| | |
|-----------------------|--|
| Enclosure dimensions | 220 mm · 260 mm · 60 mm (W·H·D) |
| Color | signal white |
| Degree of protection | IP40 |
| Operating environment | during operation: +5°C to +40°C transport / storage: -25°C to+70°C air humidity: 5% to 85% |
| Weight | without packaging: 2.1 kg with packaging: 2.4 kg |

Left even

Table 4-2: Technical data - ISDN port battery requirements

| | |
|-------------------------|---|
| Voltage | 12 V |
| Capacity | 1.3 Ah |
| Additional requirements | Cycle and parallel standby mode Expected lifetime: at least 6 years Lead-gel accumulator Recovery after deep discharge Maximum charging current 1 A Low-maintenance / maintenance-free VDS-number |

Table 4-3: Technical data - ISDN port power supply

| | |
|---------------------------|-----------------------------|
| Input voltage | 230 V |
| Input frequency | 50 Hz |
| Maximum power consumption | 35 W Protection Class II |

Table 4-4: Technical data - ISDN port S₀-interface

| | |
|---------------------|--------------------------------------|
| Transmission method | 4-wire-duplex transmission |
| Channel structure | 2B+D, synchronization and monitoring |
| Line code | AMI (modified) |
| Total bit rate | 192 kbps |
| Useable bit rate | 144 kbps |

Table 4-4: Technical data - ISDN port S₀-interface

| | |
|-------------------|---|
| Bus configuration | short passive bus, working range: <= 220 m extended passive bus, working range: <=1100 m |
| Supply concept | acc. to ITU-I.430 |
| Wattage | <= 4.5 W in normal mode <= 410 mW in emergency mode |

Right odd

Left even

Standards and certifications

ETSI ISDN specifications

- [1] ETSI Recommendation ETS 300 347-1; Signalling Protocols and Switching (SPS); V interfaces at the digital Local Exchange (LE); V5.2 interface for the support of Access Network (AN); Part 1: V5.2 interface specification
- [2] ETSI Recommendation ETS 300 012; Integrated Services Digital Network (ISDN); Basic user-network interface; Layer 1 specification and test principles
- [3] ETSI Recommendation ETS 300 297; Integrated Services Digital Network (ISDN); Access digital section for ISDN basic access EMC recommendations
- [4] DIN EN 50081-1; Basic technical requirements for unwanted emissions in residential buildings
- [5] DIN EN 50082-1; Basic technical requirements for interference immunity in residential buildings
- [6] DIN EN 55022 Class B; Limit values and measuring techniques for radio interferences in the information-technology sector
- [7] DIN EN 60950 (IEC 950); Safety requirements for electric facilities in the information-technology sector
- [8] EMVG; Law on electromagnetic compatibility, issued 30. August 1995
- [9] EN 61000-4-2 till 6/11; EMC Testing procedures for interference immunity

Other relevant specifications

- [10] ITU-T Specification I.430; (11/95) Basic user - network interface - Layer-1
- [11] ITU-T I.412; ISDN user network interfaces - interface structures and access capabilities
- [12] ETSI ETS 300 047; Integrated Services Digital Network (ISDN); Basic access - safety and protection
- [13] ETSI ETS 300 019 Equipment Engineering (EE); Environmental conditions and environmental tests for telecommunications equipment;

Right odd

Left even

Appendix A: Wiring the S₀-bus types

This appendix shows the wiring diagrams for the short and extended passive bus types of the S₀-bus.

Figure 5-1: Wiring of the short passive bus

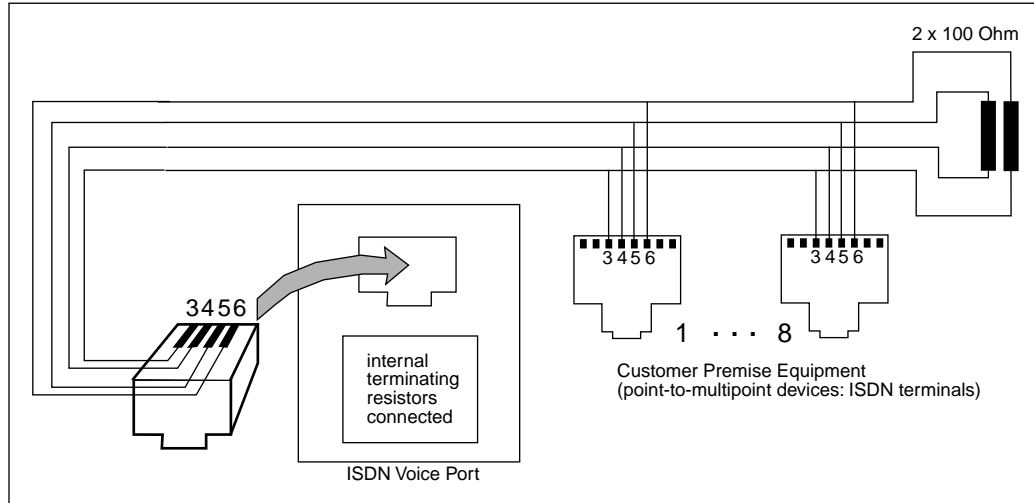

The short passive bus variant is used to connect up to eight point-to-multipoint devices (for example ISDN telephones) to the S₀-bus.

The extended passive bus variant is used to connect a point-to-point device (for example a PBX) to the ISDN Voice Port. While the short passive bus supports up to eight terminals only one device can be connected in the point-to-point configuration.

Left even

Figure 5-2: Wiring of the extended passive bus

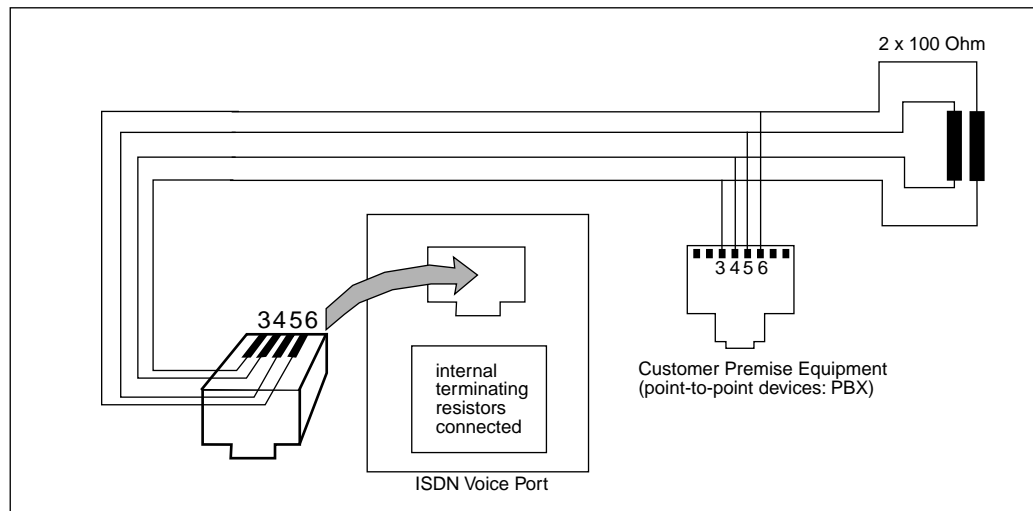

Appendix B: Terms

This appendix lists the terms used in this document.

| <i>Term</i> | <i>Meaning</i> |
|-------------|---|
| BRA | Basic Rate Access |
| CATV | CABLE TeleVISION |
| CE | Conformité Européenne (European standard) |
| DIP switch | Dual-In-line Package switch |
| ETSI | European Telecommunications Standards Institute |
| HFC | Hybrid Fibre-Coax |
| ISDN | Integrated Services Digital Network |
| ITU | International Telecommunication Union |
| LED | Light-Emitting Diode |
| NTBA | Network Termination Basic Access |
| PABX | Private Automatic Branch Exchange |
| PCB | Printed Circuit Board |
| RF module | Radio Frequency module |
| SMD | Surface-Mounted Device |
| TE | Terminal Equipment |
| TR | Terminating Resistor (100 Ohm) |
| TV | TeleVISION |

Left even

Back page

Cornerstone

ISDN Voice Port Installation Guide

© 2001 ARRIS
All rights reserved

The information in this document is subject to change without notice. The statements, configurations, technical data, and recommendations in this document are believed to be accurate and reliable, but are presented without express or implied warranty. Users must take full responsibility for their applications of any products specified in this document. The information in this document is proprietary to ARRIS.

ARRIS, ARRIS Interactive, and Voice Port are trademarks of ARRIS Licensing Company. Cornerstone is a registered trademark of ARRIS Licensing Company. AccessNode is a registered trademark of Nortel Networks. All other trademarks and registered trademarks are the property of their respective holders.

Document number: ARSVD00396
Release 8.1 Standard 1.0
September 2001

